



KOALA 90-XTRA



**REFRIGERATED CONTAINER FOR THE
TRANSPORT OF TEMPERATURE-
CONTROLLED PRODUCTS**



www.melform.com



KOALA 90-XTRA

- Brand: MELFORM
- Country of origin: ITALY
- Customs code: 84181080
- Compatible with food contact
- Color: grey/blue
- Dual power supply: 12Vdc and 230Vac
- Technology: rotomoulding
- Warranty: 24 months
- Fully recyclable at the end of its operational life

MANUFACTURING MATERIALS

POLYETHYLENE: internal and external walls of the container and door; suitable for food contact.

POLYURETHANE: insulating material between the walls of the container and the door, free of CFC and HCFC.

SILICONE RUBBER: gasket.

ALUMINUM: hinge.

STAINLESS STEEL: gripping handles, closures.

GALVANIZED STEEL: carter.

AVAILABLE MODELS

| MODEL | SKU | EAN CODE | EXT. DIM. (mm) | INT. DIM. (mm) | CAPACITY (l) | WEIGHT (kg) |
|--|--------------|---------------|----------------|----------------|--------------|-------------|
| TOP COOLING UNIT, STATIC 0°C +40°C | KD90AFTSDZM0 | 8022949243623 | 530x605xh985 | 335x415xh620 | 86 | 37 |
| TOP COOLING UNIT, STATIC -25°C +40°C | KD90AFTSBZM0 | 8022949231194 | 530x605xh985 | 335x415xh620 | 86 | 37 |
| BACK COOLING UNIT, STATIC 0°C +40°C | KD90AFDSDZM0 | 8022949243609 | 530x765xh830 | 335x415xh620 | 86 | 37 |
| BACK COOLING UNIT, STATIC -25°C +40°C | KD90AFDSBZM0 | 8022949233532 | 530x765xh830 | 335x415xh620 | 86 | 37 |

DIMENSIONAL DRAWING

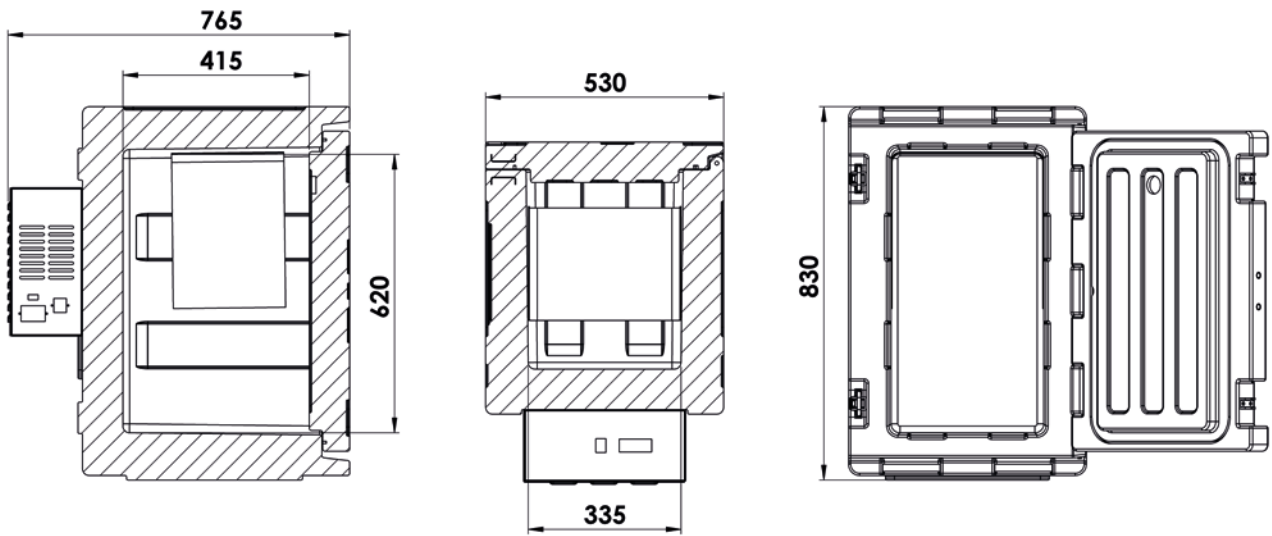

KOALA 90-XTRA BACK COOLING UNIT

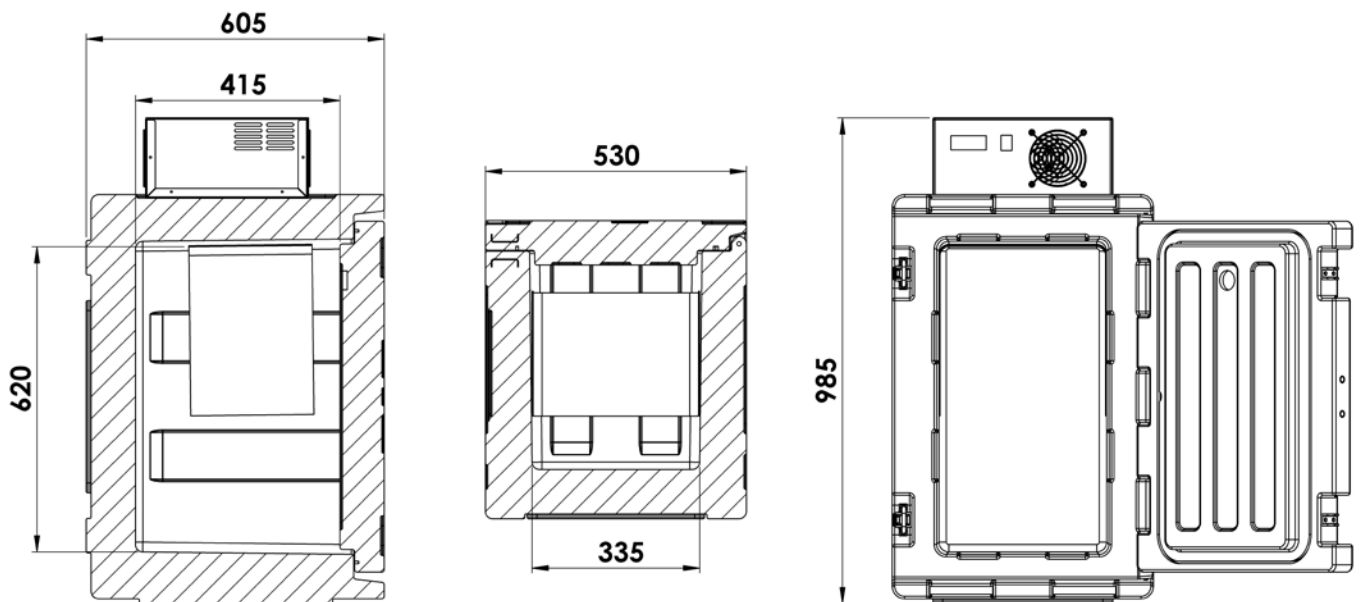

KOALA 90-XTRA TOP COOLING UNIT

FEATURES COOLING UNIT



Static refrigeration unit version equipped with a "roll-bond" type static evaporator.

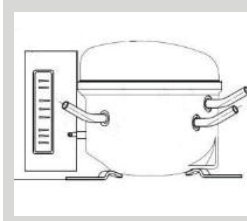

Hermetic compressor with electronic control unit for regulation and control equipped with surge protection

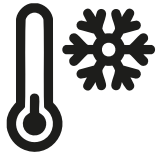

Guaranteed refrigeration unit performance for ambient T-use: **+10°C to +30°C**
Container (isothermal body) guaranteed for use: **-30°C to +100°C**



Cables **230Vac 50-60Hz** power supply

(standard equipment)



Cables for **12Vdc** power supply with Anderson terminal on the KOALA side and cigarette lighter plug

(standard equipment)



Cables for **12Vdc** power supply with Anderson terminals

(standard equipment)



Temperature regulation and control with programmable digital thermostat



USB datalogger available (on request) to record temperature data during transport

Degree of accuracy: **+/-0,5 °C**

Refrigerant gas: **R134a**

Overall heat transfer coefficient: **K=0,29 W/m²K**

PRODUCT FEATURES



Adjustable stainless steel latches with seal eyelet



Door sealing system easily removable



Monobloc structure, without edges, joints and welds



Reinforced structure to ensure durability



Integrated stainless steel gripping handles



Metal handling trolley with polystyrene coating and ABS corner guards.

- 4 non-marking rubber wheels, 100 mm diameter
- 2 swivel wheels
- 2 wheels with brakes

| MODEL | SKU | ABSORPTION NOMINAL | FUSES |
|--|--------------|-------------------------------|--------------------------------|
| KOALA 90-XTRA TOP COOLING UNIT, STATIC DA 0°C A +40°C | KD90AFTSDZM0 | 0,8A at 230Vac 8A at 12Vdc | 4A per 230Vac 15A per 12Vdc |
| KOALA 90-XTRA TOP COOLING UNIT, STATIC -25°C TO +40°C | KD90AFTSBZM0 | 0,8A at 230Vac 8A at 12Vdc | 4A per 230Vac 15A per 12Vdc |
| KOALA 90-XTRA BACK COOLING UNIT, STATIC 0°C TO +40°C | KD90AFDSDZM0 | 1,3A at 230Vac 9A at 12Vdc | 4A per 230Vac 15A per 12Vdc |
| KOALA 90-XTRA BACK COOLING UNIT, STATIC -25°C TO +40°C | KD90ADTSBZM0 | 1,3A at 230Vac 9A at 12Vdc | 4A per 230Vac 15A per 12Vdc |

ACCESSORIES

| ACCESSORIES | SKU | EXT. DIM. (mm) | WEIGHT (kg) |
|-----------------------------------|----------|----------------|-------------|
| Handling trolley | THD90AF1 | 545x610xh170 | 6,5 |
| USB Data Logger Range -30°C +70°C | AFG007 | | |