



MODULAR SYSTEM AF 12

GN 1/1



www.melform.com



- Brand: MELFORM
- Country of Origin: ITALY
- Customs code: 39231090
- Compatible with food contact
- Color: grey/blue
- Technology: rotomoulding
- Warranty: 24 months
- Fully recyclable at the end of its operational life

MODULAR SYSTEM

AF 12

FEATURES

- 90-liter capacity per section with 12 internal runners, suitable for various GN 1/1 pan configurations.
- Practical and flexible modular structure: quick assembly and disassembly for easy use and cleaning.
- Simultaneous transport of hot, chilled and frozen food thanks to two separate and thermally insulated cells.
- Removable locking kit for securing an AF12 container to the trolley or for assembling two stacked units.



MANUFACTURING MATERIALS

POLYETHYLENE: internal and external walls of the container and the door, trolley; suitable for food contact.

POLYURETHANE: insulating material between the walls of the container and the door, CFC and HCFC-free.

SILICONE RUBBER: gasket.

STAINLESS STEEL: handling handles, wheel support, locking kit.

FIBERGLASS-REINFORCED POLYAMIDE: hinges, closures.

RUBBER AND POLYPROPYLENE: wheels (rubber tread and polypropylene core).

AVAILABLE MODELS

| MODELS | SKU | COMPOSITION | EXT. DIM. (mm) | INT. DIM. (mm) | CAPACITY (l) | WEIGHT (kg) |
|--|----------|--|----------------|---------------------------------|--------------|-------------|
| AF 12 MODULAR SYSTEM FRESH/FRESH | AF12M002 | -no. 2 AF12 passive containers -no. 1 trolley -no. 1 locking kit | 505x685x1480H | 330x533x515H per each module | 180 | 41 |
| AF 12 MODULAR SYSTEM FRESH/HOT | AF12M003 | -no. 1 AF12 passive container -no. 1 AF12 digital heated container -no. 1 trolley -no. 1 locking kit | 505x720x1480H | 430x650x530H per each module | 180 | 43,5 |
| AF 12 MODULAR SYSTEM FRESH/HOT | AF12M005 | -no. 1 AF12 passive container -no. 1 AF12 analog heated container -no. 1 trolley -no. 1 locking kit | 505x720x1480H | 430x650x530H per each module | 180 | 43,5 |
| AF 12 MODULAR SYSTEM HOT/HOT | AF12M004 | -no. 2 AF12 digital heated containers -no. 1 trolley -no. 1 locking kit | 505x720x1480H | 330x533x515H per each module | 180 | 46 |
| AF 12 MODULAR SYSTEM HOT/HOT | AF12M006 | -no. 2 AF12 analog heated containers -no. 1 trolley -no. 1 locking kit | 505x720x1480H | 330x533x515H per each module | 180 | 46 |
| AF 12 MODULAR SYSTEM HOT/FROZEN | AF12M007 | -no. 1 AF12 digital heated container -no. 1 Koala 90 refrigerated container -no. 1 trolley -no. 1 locking kit | 505x865x1480H | 330x533x505H per each module | 180 | 53,8 |
| AF 12 MODULAR SYSTEM HOT/FROZEN | AF12M008 | -no. 1 AF12 analog heated container -no. 1 Koala 90 refrigerated container -no. 1 trolley -no. 1 locking kit | 505x865x1480H | 330x533x505H per each module | 180 | 53,8 |

DIMENSIONAL DRAWING

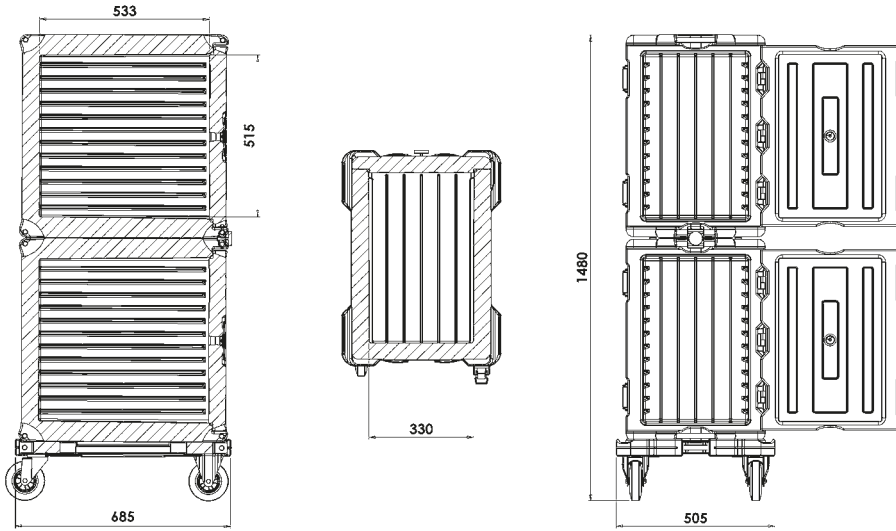

AF12 modular system fresh/fresh

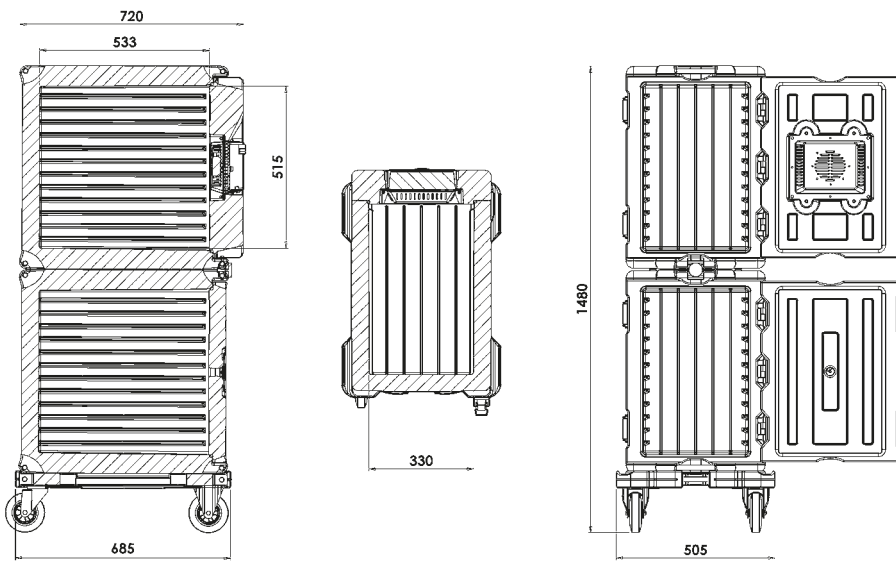

AF12 modular system fresh/hot

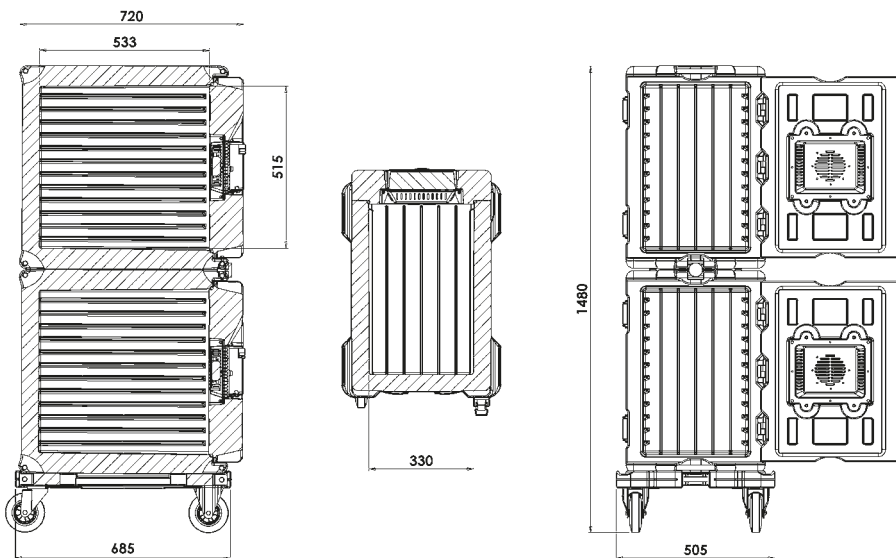

AF12 / KOALA 90 modular system frozen/hot

PRODUCT FEATURES



Each cell is equipped with 12 runners at constant pitch (40 mm; see dimensional diagram).



Equipped with a door that opens up to 240° and is easily removable, to facilitate cleaning operations.



Easily removable door gasket.



Adjustable vent valve.



Provided with integrated stainless steel handles.



Stainless steel GN 1/1 grid available on request.



Stainless steel locking kit for securing two stacked containers together.



Provided with shock-proof and stress-resistant hinges.



Melform closing hooks in impact-resistant material.



Available (on request) USB datalogger to record temperature during transport



Eutectic plates:
• hot (red)
• chilled (pink)
• frozen (blue)
• frozen plus (green / grey)

to increase thermal maintenance performance over time



Handling trolley:
• load capacity 150 kg;
• 4 non-marking rubber wheels with PP core;
• wheel diameter: 125 mm;
• 2 fixed wheels;
• 2 swivel wheels, 1 with brake.

ACCESSORIES

| ACCESSORIES | SKU | COLOR | EXT. DIM. (mm) | WEIGHT (kg) |
|----------------------------------|----------|--------------|----------------|-------------|
| Stainless steel grid | AEA020 | | GN 1/1 | 1,3 |
| Polyethylene trolley | THS20009 | | 505x685xh205 | 8 |
| Eutectic plate Hot +70°C | PEGS0003 | RED | GN 1/1 | 4 |
| Eutectic plate Chilled +3°C | PEGS0001 | ROSE | GN 1/1 | 4 |
| Eutectic plate Frozen -21°C | PEGS0002 | BLUE | GN 1/1 | 4 |
| Eutectic plate Frozen plus -21°C | PEGS9008 | GREY / GREEN | GN 1/1 | 4 |
| Fixing kit for modular system | RRR139 | | | 1,2 |
| USB Data logger -30°C +70°C | AFG007 | | | |